

PRESSURE SWITCHES

PS91

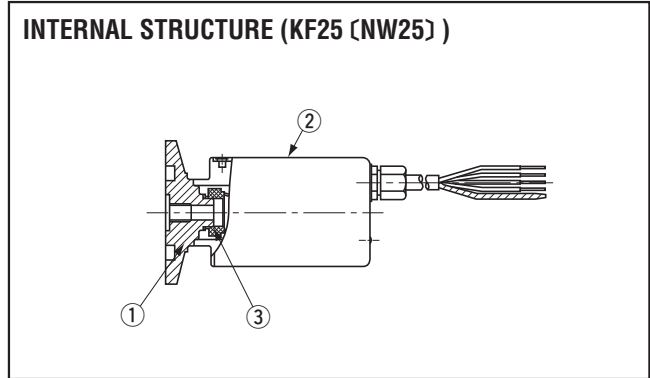
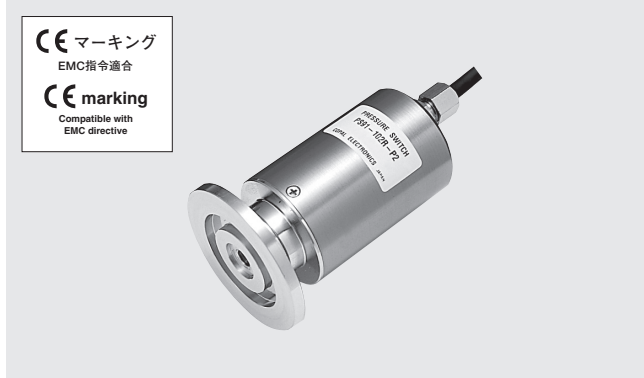

FEATURES

- Can be used in High vacuum
- Selection of Quick-release coupling (ISO standard) and Gasket joint
- Switch setting adjustable by 2 VRs on the back

Part name		Material
①	Fitting	SUS316L
②	Housing	Aluminum
③	Sensor module	SUS316L

MODEL NUMBER DESIGNATION

PS91 - 102V - N2 K2

Series name

Rated pressure range
102V : -100 ~ 10 kPa

Pressure reference

- N1 : NPN (Upper and upper limit mode)
- N2 : NPN (Upper and lower limit mode)
- P1 : PNP (Upper and upper limit mode)
- P2 : PNP (Upper and lower limit mode)

Fitting

- K2 : Flange joint KF25 (NW25)
- VC : Gasket joint (9/16-18UNF)

LIST OF MODEL NUMBERS

Rated pressure range	Switch output interface	Gauge	
		K2 : Flange joint KF25 (NW25)	VC : Gasket joint (9/16-18UNF)
102V	NPN (Upper and upper limit mode)	PS91-102V-N1K2	PS91-102V-N1VC
	NPN (Upper and lower limit mode)	PS91-102V-N2K2	PS91-102V-N2VC
	PNP (Upper and upper limit mode)	PS91-102V-P1K2	PS91-102V-P1VC
	PNP (Upper and lower limit mode)	PS91-102V-P2K2	PS91-102V-P2VC

STANDARD SPECIFICATIONS

Item		Model number	PS91
			102V
General specifications	Pressure reference		Gauge
	Rated pressure range	kPa	- 100 ~ 10
	Maximum pressure	kPa	200
	Break-down pressure	kPa	300
	Operating temp. range	°C	- 20 ~ 80
	Compensated temp. range	°C	0 ~ 50
	Pressure medium		Corrosive gases/liquids compatible with SUS 316L
	Pressure port		K2 (Flange joint : KF25) 、 VC (9/16-18UNF)
	Net weight	g	Approx. 140
Power	Supply voltage	V DC	12 ~ 24 ± 10 %
	Consumption current	maximum	15
Switch output	No. of outputs		2(NPN / PNP open collector)
	Setting method		Adjustable by VR
	Adjustable range		0 ~ 100 %
	Output mode		Upper and upper limit mode / Upper and lower limit mode
	Accuracy 0 ~ 50 °C(Reference temp.: 25 °C)	%F.S.	± 3
	Hysteresis	%F.S. maximum	2
	Response	ms	Approx. 2

ENVIRONMENTAL CHARACTERISTICS

Test item	Test conditions (At 25 ± 5 °C)	Permissible change
Vibration	10 ~ 500 Hz, 1.5 mm maximum/98.1 m/s ² , 3 directions for 2 hours each	Switch operating pressure : ± 2 %F.S. maximum ※1
Shock	490 m/s ² , 3 directions for 3 times each	
Pressure cycling	0 ~ Rated pressure, 10 ⁶ cycles	
Moisture resistance	40 °C, 90 ~ 95 %RH, 240 hrs.	
EMC	EMI : EN55011: 2007, A2 : 2007 Group 1, class B EMS : EN61326-1 : 2006 Table 2	Switch operating pressure: ± 5 %F.S. maximum ※2

※1 Working pressure of switch output is variation ± 2 %F.S. before or after test.

※2 Working pressure of switch output is variation ± 5 %F.S. during EMC test.

PS91

PRESSURE SWITCHES

SWITCH OUTPUT SCHEMATICS

● N1/P1 type

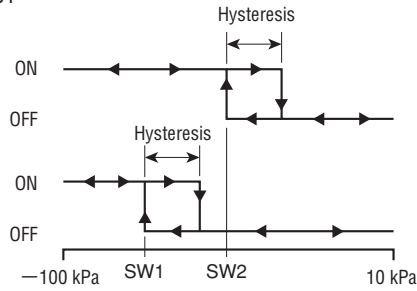

● N2/P2 type

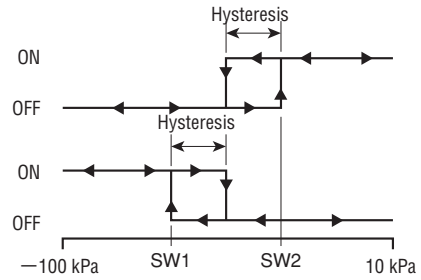

INTERNAL ELECTRICAL SCHEMATICS

● NPN

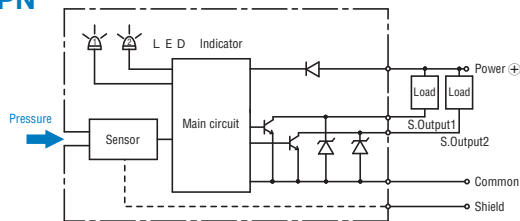

● PNP

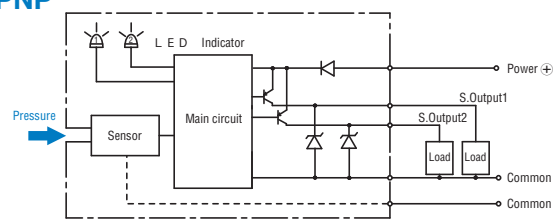

OUTLINE DIMENSIONS

Unless otherwise specified, tolerance : ± 0.5 (Unit: mm)

● K2

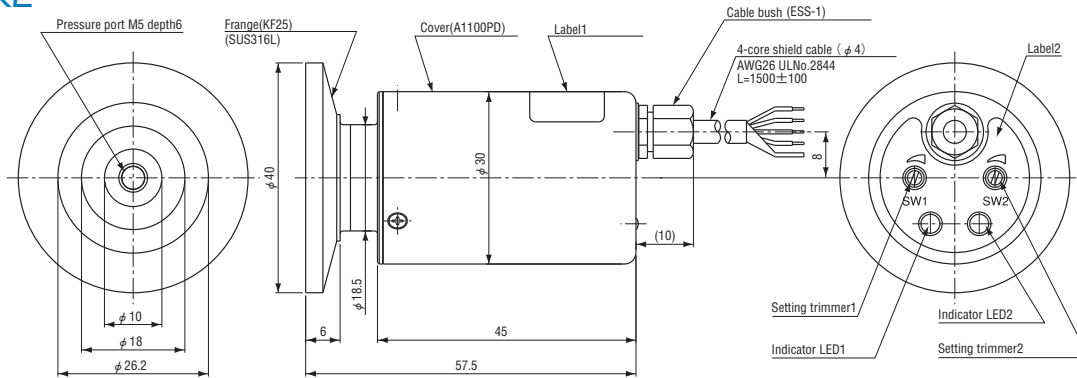

● VC

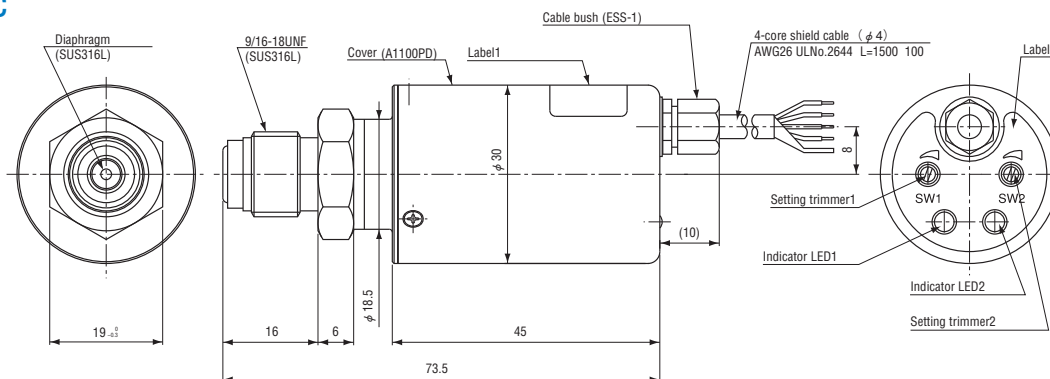

Wire color	Connection
Red	Power
Green	Switch output 1
White	Switch output 2
Black	Common
Shield	Fitting



SCIGATE AUTOMATION (S) PTE LTD
 No.1 Bukit Batok Street 22 #01-01 Singapore 659592
 Tel: (65) 6561 0488 Fax: (65) 6562 0588
 Email: sales@scigate.com.sg Web: www.scigate.com.sg
 Business Hours: Monday - Friday 8.30am - 6.15pm